

Field mapping: Computer calculation and analytical approximation

P. Gillis, J.-L. Bailly, V. P. Henri, and S. Peto

Physique expérimentale, Faculté de Médecine, Université de Mons-Hainaut, Mons B-7000, Belgium

(Received 19 October 1987; accepted for publication 17 February 1988)

A procedure for the calculation of the magnetic field generated by various coils is explained and compared to a 1902 approximation by Lyle. This approximation consists of substituting two single loops for a coil with a finite rectangular section. Both methods (exact and approximate) are applied in the case of two magnets used in the design of a nuclear magnetic relaxometer; the agreement between them is quite satisfactory, so that Lyle's approximation can be used even off-axis, outside the region for which it was established.

I. INTRODUCTION

Magnetic field mapping has been known for a long time as a very important problem in many physics experiments, such as elementary particles, plasma confining, spectroscopy, etc.¹ It is also important in some common advanced undergraduate experiments, for example, when measuring the em ratio.²

We have been led to this problem through nuclear magnetic resonance, more precisely, through relaxometry—i.e., measuring nuclear magnetic relaxation times in a wide range of static magnetic fields. Field mapping has been important in NMR since its inception. It was first noticed in the 1950s³ that the inhomogeneity of the static field into which the sample recovers its magnetic equilibrium considerably shortens transverse relaxation (i.e., the vanishing of the magnetization component orthogonal to the static field): Spins precessing at different frequencies rapidly lose the phase coherence they had just after the initial pulse. This problem was solved when Carr and Purcell proposed a pulse sequence to minimize this phenomenon⁴; it consists of sending 180° pulses at regular time intervals, so that a spin echo appears at the center of the delay separating two consecutive 180° pulses. The refocusing of the signal eliminates the reversible decay due to the field inhomogeneity.

More recently, the development of MRI (magnetic resonance imaging) was made possible by important improvements in coil design, but the users were confronted with new problems. The NMR signal giving the image depends on many parameters: instrumental parameters, local nuclear concentration, and the relaxation times T_1 and T_2 , i.e., the times for the magnetization component, respectively, parallel and orthogonal to the field to recover its equilibrium value. This multiparametric dependence complicates the interpretation of the images. In particular, T_1 , the longitudinal relaxation time of water protons, characterizes the studied tissue or heterogeneous system and depends on the value of the magnetic field into which the spin relaxes.⁵ The knowledge of this dependence, called dispersion, is thus an important factor in good understanding of the images.

We have built an apparatus able to measure longitudinal relaxation times of water protons in a static field ranging from 0.01 to 100 G. This device, called a relaxometer, is a field cycling system, first built and described by Koenig and Brown⁵; it is characterized by a very fast commutation of the fields, so that the signal detection always occurs at the same frequency. Our system, following the idea of Borcard,⁶ detects the free induction decay of the magnetization in the Earth's field. Problems of inhomogeneity when de-

tecting are thus obviously eliminated thanks to the natural homogeneity of the Earth's field, but they remain during the relaxation: To obtain a field of 10^{-2} G the Earth's field must be carefully compensated for. On the other hand, the nature of our measurements imposes a careful definition of the static field: We study the longitudinal relaxation time's dependence against the field into which the sample relaxes. The accuracy of the field knowledge (and its homogeneity) directly gives the value of the errors on the abscissa of our dispersion curves. Our system is made of three coils whose axes form a trirectangle trihedral (see Fig. 1, reproduced from Ref. 7). Figure 2 shows the field experienced by the sample during the three stages of one cycle. The sample is first polarized along the x axis ($B = B_p$). It is generally admitted that its magnetization is in equilibrium with the field when the sample has been submitted to the field for a time greater than or equal to five times the relaxation time. This first stage is thus relatively long, of the order of or greater than 1 s.

The current going through the coil is then abruptly modified, so that the sample is now immersed in the relaxation field (B_R)—the field for which we want to know T_1 . During these two stages, the Earth's field B_T must be compensated for and the coil assigned to this compensation, with its axis aligned on the z axis, must be energized. After a time τ , which varies from one cycle to another, all currents are canceled. The sample is then subjected only to B_T , the Earth's field (defining the z direction and perpendicular to its magnetization), and the magnetization M starts

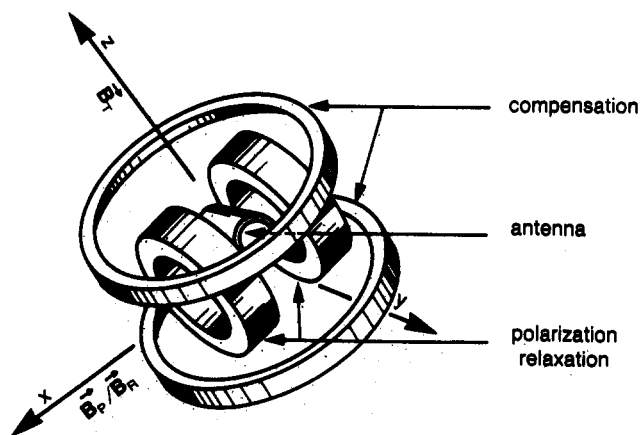

Fig. 1. Experimental setup and spatial configuration of the magnetic fields.

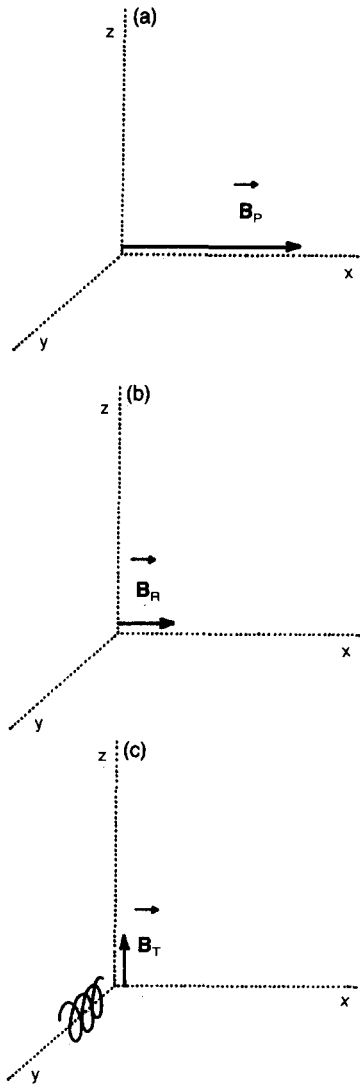

Fig. 2. The magnetic field experienced by the sample during the three stages of one cycle, giving the longitudinal magnetization at time $t = \tau$: It is the initial value of the free-induction signal detected by the antenna. (a) From $t = 0$ to $t = 5T_1$, where T_1 is the longitudinal nuclear magnetic relaxation time. B_J is compensated for; (b) From $t = 5T_1$ to $t = 5T_1 + \tau$. B_J is compensated for; (c) Detection: The magnetization precesses around B_T , in the x - y plane, inducing a signal in the antenna aligned on the y axis.

precessing, inducing a current in the third coil, the antenna, with an axis parallel to the y axis. The initial value of this signal is proportional to $M(\tau)$ in B_R . The decay of the magnetization is reconstituted by varying τ .

The field for the Earth's field compensation is generated by a pair of Helmholtz coils. B_p and B_R are generated by a pair of coils separated by a distance slightly larger than their radius ($d = 1.2R$). The antenna is a solenoid. Field mapping is important particularly for B_R .

Writing an analytical expression for the field is straightforward when assimilating the coils to simple wires. We recall these expressions in Sec. II. The problem of estimating the effect of the finite sizes of the coils is not new. We found a 1902 work by Lyle⁸ defining an approximation for answering the question. We present a revised version of his work, using the field as an unknown function instead of the scalar potential, as was done by Lyle.

Finally, we compare in Sec. III the results of Lyle's approximation with an exact numerical calculation.

II. ANALYTICAL APPROXIMATION FOR THE FIELD CALCULATION

The first step of our analysis consists of recalling the expression for the magnetic field due to a current I going through a single loop of radius a .

The use of cylindrical coordinates is adapted to the symmetry of the problem. Let z be the direction of the axis of the circular loop, and (ρ, θ) be the polar coordinates in the plane of the loop. We get from the Biot-Savart law⁹ for the field at point $P(z, \rho, \theta)$,

$$B_z = \frac{\mu_0 I}{4\pi} k(a\rho)^{-1/2} \times \left(K(k) - \frac{1 - k^2/2(a/\rho + 1)}{1 - k^2} E(k) \right),$$

$$B_\rho = \frac{\mu_0 I}{4\pi} kz(a\rho^3)^{-1/2} \times \left[\left(\frac{1 - k^2/2}{1 - k^2} \right) E(k) - K(k) \right], \quad (1)$$

$$B_\theta = 0,$$

where μ_0 is the magnetic permeability of the vacuum, where

$$k^2 = 4a\rho / [(a + \rho)^2 + z^2] \leq 1,$$

and where $K(k)$ and $E(k)$ are, respectively, the complete elliptic integrals of the first and second kind.

We thus have

$$B_\theta = B_\rho = 0,$$

$$B_z = (\mu_0 I / 2) [a^2 / (a^2 + z^2)^{3/2}], \quad (2)$$

when $\rho = 0$, i.e., on the axis.

The value of the field on-axis is the basis of Lyle's approximation.

Let us consider the case where the field is generated by a coil of N loops, with a length η along z , and a depth ξ along ρ . Our coil is thus characterized by two parameters, ξ and η . Lyle's idea consists of defining an equivalent system made with only two loops, each of them run by a current $NI/2$. The aim of the calculation is to locate these loops in such a way that the field on-axis would be identical to the second order in ξ and η to the field due to the coil. Lyle identified the magnetic scalar potential for both systems; we prefer to present the same idea using the field.

Let A_i be the radius of loop i and Z_i be the projection on z of the distance between P and the plane of loop i . If a is the mean radius of the coil, and z is the coordinate of P against the medium plane of the coil, we have

$$A_i = a + u_i, \quad \text{and} \quad Z_i = z + v_i,$$

with $u_i, v_i \ll a, \xi/2$, and $\eta/2$ being, respectively, the maxima of $|u_i|$ and $|v_i|$.

The field due to loop i may be expanded in a Taylor series at point $P(Z_i, 0, 0)$:

$$B_{z,i} = B^{(0)} + B^{(1)}u_i + B^{(2)}v_i + \frac{1}{2}B^{(3)}u_i^2 + B^{(4)}u_i v_i + \frac{1}{2}B^{(5)}v_i^2 + \dots$$

Here, $B_{z,i}$ can easily be averaged on u_i and v_i , replacing the

discrete averaging by a continuous one,

$$\langle B_z \rangle = \frac{1}{\xi\eta} \int_{-\xi/2}^{\xi/2} du \int_{-\eta/2}^{\eta/2} dv B_z(u,v). \quad (3)$$

We obtain, to the second order in ξ, η ,

$$\langle B_z \rangle = B^{(0)} + B^{(3)}(\xi^2/24) + B^{(5)}(\eta^2/24), \quad (4)$$

i.e., starting from expression (2)

$$\langle B_z \rangle = \frac{\mu_0 NI}{2a} \left[(1+z'^2)^{-3/2} + \frac{15}{24} \left(\frac{\eta^2 - \xi^2}{a^2} \right) z'^2 (1+z'^2)^{-7/2} + \frac{1}{24} \left(\frac{2\xi^2 - 3\eta^2}{a^2} + 2 \frac{\xi^2}{a^2} z'^2 \right) (1+z'^2)^{-5/2} \right], \quad (5)$$

where $z' = z/a$.

Equation (5) can be expanded in powers of z' ,

$$\langle B_z \rangle = \frac{\mu_0 NI}{2a} \sum_{n=0}^{\infty} \left(1 + \frac{(2n+1)(2n+2)\xi^2 - (2n+1)(2n+3)\eta^2}{24a^2} \right) \frac{(2n+1)!!}{(2n)!!} \left(-\frac{z^2}{a^2} \right)^n. \quad (6)$$

Let us now define the equivalent system if $\eta > \xi$: two identical coaxial loops, of radius r , the distance between them being 2β . We get from (2)

$$B_z = \frac{\mu_0 NI}{4} \left(\frac{r^2}{[r^2 + (z-\beta)^2]^{3/2}} + \frac{r^2}{[r^2 + (z+\beta)^2]^{3/2}} \right),$$

or, to the second order in β and expanding the result in a Taylor series, the variable being z/r ,

$$B_z = \frac{\mu_0 NI}{2r} \sum_{n=0}^{\infty} \frac{(2n+1)!!}{(2n)!!} \left(1 - \frac{(2n+1)(2n+3)}{2} \frac{\beta^2}{r^2} \right) \left(-\frac{z^2}{r^2} \right)^n. \quad (7)$$

We now just have to identify (6) and (7), setting $r = a(1 + \delta)$. The solution

$$\beta^2 = (\eta^2 - \xi^2)/12 \quad (8)$$

and

$$\delta = \xi^2/24a^2 \quad (9)$$

is such that, to first order in δ , expansions (6) and (7) are identical for all n .

It can easily be shown that solutions (8) and (9) are unchanged when z is larger than a and r . Furthermore, identification is also possible for $\eta < \xi$.

An analogous calculation shows that for $\eta < \xi$ the system equivalent to the coil is made of two concentric and coplanar loops each run by a current $NI/2$, with radii $r \pm \delta$, where $r = a(1 + \eta^2/24a^2)$ and $\delta^2 = (\xi^2 - \eta^2)/12$.

The idea of Lyle is simple and clear: A cylindrical coil made of coaxial and parallel loops can be characterized by its radial depth (ξ) and its axial length (η). On-axis the field generated by this coil is equivalent to the field generated by two loops (either parallel and with equal radii, or concentric and coplanar), to second order against parameters ξ/a and η/a , a being the mean radius of the loops.

In Sec. III we will consider the results obtained with the same approximation, but off-axis, i.e., outside the domain for which it was originally established.

III. DETERMINATION OF THE FIELD OFF-AXIS

The field produced by a coil can be calculated at any point starting from Eqs. (1). It must be summed over the contributions of each loop, which amounts to varying a and z (and thus k) for a cylindrical magnet.

On the other hand, the same equations (1) allow us to obtain the field generated by the two equivalent loops of Lyle. We have compared the results obtained with both methods (exact and approximate) for the two different magnets involved in our device.

The first magnet is the magnet generating the polarization and relaxation fields, made of two identical coils of 1216 loops each. The parameters of the system are $a = 10.68$ cm, $\eta = 4.00$ cm, $\xi = 3.36$ cm. The distance between the central planes of the two coils is 13.00 cm. Lyle's equivalent system consists of four parallel loops, with a radius

$$r = a(1 + \delta), \quad \delta = 0.0041,$$

the distance between the two loops of each pair is

$$2\beta = 1.25 \text{ cm.}$$

The second magnet is the one that compensates the Earth's field, made of two Helmholtz coils, characterized by the following parameters:

$$\alpha = 22.0825 \text{ cm, } \eta = 2.00 \text{ cm, } \xi = 0.165 \text{ cm,}$$

Table I. Spatial variation of the z component of the magnetic field (in G/A) obtained by the complete numerical calculation for the first magnet described in the text. Here, z is the coordinate along the axis of the coil, and ρ is the distance to this axis. The broken line shows the region where the field variation is of the order of 1%.

ρ (cm)	43.16	44.08	47.18	53.74	66.38	
10	43.16	44.08	47.18	53.74	66.38	
9	55.63	57.25	62.67	74.09	98.18	
8	66.31	68.17	74.20	85.76	104.89	
7	74.57	76.29	81.56	90.60	102.78	
6	80.47	81.84	85.89	92.27	99.90	
5	84.42	85.44	88.34	92.65	97.39	
4	86.95	87.67	89.68	92.53	95.44	
3	88.49	88.99	90.38	92.26	94.01	
2	89.38	89.74	90.72	91.99	93.04	
1	89.83	90.12	90.87	91.81	92.48	
0	89.97	90.23	90.91	91.74	92.30	
	0	1	2	3	4	z (cm)

Table II. Difference in percentage between the result in Table I and the z component of the field obtained by substituting one single loop for one coil.

ρ (cm)						
10	-1.27	-1.35	-1.57	-1.62	1.38	
9	-1.72	-1.84	-2.22	-3.00	-5.55	
8	-1.85	-1.95	-2.30	-2.99	-4.01	
7	-1.77	-1.82	-1.97	-2.10	-1.82	
6	-1.58	-1.58	-1.56	-1.41	-0.93	
5	-1.37	-1.35	-1.25	-1.01	-0.59	
4	-1.19	-1.15	-1.02	-0.79	-0.45	
3	-1.05	-1.00	-0.88	-0.67	-0.39	
2	-0.95	-0.91	-0.79	-0.60	-0.37	
1	-0.89	-0.85	-0.74	-0.57	-0.36	
0	-0.87	-0.83	-0.72	-0.56	-0.35	
	0	1	2	3	4	z (cm)

Table III. Difference in percentage between the result in Table I and the z component of the field obtained by substituting Lyle's two loops for one coil.

ρ (cm)						
10	0.73	0.83	1.28	2.94	10.97	
9	0.17	0.20	0.30	0.42	-1.13	
8	-0.27	-0.32	-0.52	-1.15	-2.72	
7	-0.58	-0.64	-0.86	-1.28	-1.71	
6	-0.74	-0.79	-0.93	-1.12	-1.21	
5	-0.82	-0.84	-0.91	-0.98	-0.96	
4	-0.84	-0.85	-0.87	-0.88	-0.84	
3	-0.84	-0.84	-0.84	-0.82	-0.77	
2	-0.83	-0.83	-0.82	-0.78	-0.72	
1	-0.82	-0.82	-0.80	-0.76	-0.70	
0	-0.82	-0.82	-0.80	-0.76	-0.70	
	0	1	2	3	4	z (cm)

and the distance between the central planes of the coils is 22.00 cm. Each coil has 108 loops. We obtain here $\delta = 2.3 \times 10^{-6}$, and a distance between the two loops of each pair of

$$2\beta = 1.15 \text{ cm.}$$

Tables I–III refer to the first magnet described above. Table I shows the spatial variation of the z component of the field obtained by complete numerical computation.

Tables II and III show the spatial variation of the difference in percentage between the result presented in Table I, on the one hand, and two approximations, on the other hand, that we called, respectively, the simplest approximation, i.e., one loop for one coil (Table II), and Lyle's approximation (Table III), which is always for the z component of the field.

The reason for presenting the results of Table II (substituting one loop for each coil) is that using Lyle's calculation is only interesting if it gives better results than the simplest approximation we could use!

We did not consider the radial component of the field because it is very small and because the signal detected in the antenna (see Fig. 1) essentially does not depend on it.

Table I shows that the region where the field homogeneity is good (less than 1% of variation) is a cylinder about 5 cm in height (for z between -2.5 cm and $+2.5$ cm) and about 3 cm in radius, i.e., a volume smaller than the internal volume of the magnet. Tables II and III show that the concentration of the current on one or two loops decreases the field, except at the very edge of the internal volume of the magnet—a result not unexpected. Indeed, concentration of the current on one loop amounts to bringing some current elements nearer the point where the field is to be determined, which increases the field, and, simultaneously, to bringing some other elements further off from this point, which decreases the field. But the dependence of the field against the distance is such that the decrease is larger than the increase, resulting in a global diminution of the field that can thus be qualitatively understood. It can also be remarked, comparing Tables II and III, that the difference between the numerical and the approximate result increases much faster when going away from the axis for one loop than for Lyle's two loops: It remains almost every-

where less than 1% for Lyle's approximation, while it reaches 3% for the simplest approximation. This may be summarized by one observation: A volume average of the z component of the field gives 69.91 G/A for the simplest approximation, 71.37 G/A for Lyle's approximation, and 71.17 G/A for the numerical computation, i.e., 1.8% between the simplest approximation and the numerical result, and only 0.3% between Lyle's result and the numerical one.

We did not reproduce the complete results for the second magnet (the Helmholtz coils) because such magnets have been extensively studied. The conclusion for the validity of the approximations is quite coherent with our above remarks. In particular, the volumetric mean field for the internal volume of the magnet gives a difference of 2% between the simplest approximation and the numerical result, and only 0.5% when using Lyle's approximation.

The general conclusion is obvious: Lyle's approximation is useful for estimating the field due to a coil with a rectangular section, and it is even more useful off-axis than in the region near the axis for which it was originally established. With the extensive use of computers, it is now feasible to perform exact numerical field determinations. As a result of this, it is also possible to test the accuracy of analytical approximations that were used at a time when there was no computer available, and to find out the remarkable quality of these approximations.

¹See, for example, for the three topics cited: K. N. Henrichsen, *J. Phys. Colloq.* **45**, C1-937 (1984); B. Coppi and A. Taroni, in *Theory of Magnetically Confined Plasmas*, edited by B. Coppi, T. Stringer, R. Pozzoli, E. Sindoni, J. P. Carnihan, and G. G. Leotta (Pergamon, New York, 1979); and C. Brunnée, *Int. J. Mass Spectrom. Ion Process.* **76**, 125 (1987).

²J. E. Price, *Am. J. Phys.* **55**, 18 (1987).

³E. L. Hahn, *Phys. Rev.* **80**, 580 (1950).

⁴H. Y. Carr and E. M. Purcell, *Phys. Rev.* **94**, 630 (1954).

⁵S. H. Koenig and R. D. Brown, III, in *NMR Spectroscopy of Cells and Organisms*, edited by R. K. Gupta (CRC Press, Boca Raton, FL, 1987).

⁶B. Borcard, *Helv. Phys. Acta* **60**, 577 (1987).

⁷S. Conti, Ph.D. thesis, University of Geneva (1985).

⁸T. R. Lyle, *Philos. Mag.* **3**, 310 (1902).

⁹See, for example, J. D. Jackson, *Classical Electrodynamics* (Wiley, New York, 1975).